

WARMAN®

Centrifugal Slurry Pumps

Q series:

Heavy duty axial flow pumps



Excellent
Minerals
Solutions

WEIR
MINERALS

Q series: Heavy duty axial flow pumps

The WARMAN Q series are manufactured in a wide range of materials, i.e. stainless steels, monel, super duplex. The pumps are designed for all kinds of crystallisation processes. Casing design pressure up to 10 bar. Casing design temperature up to 200°C.

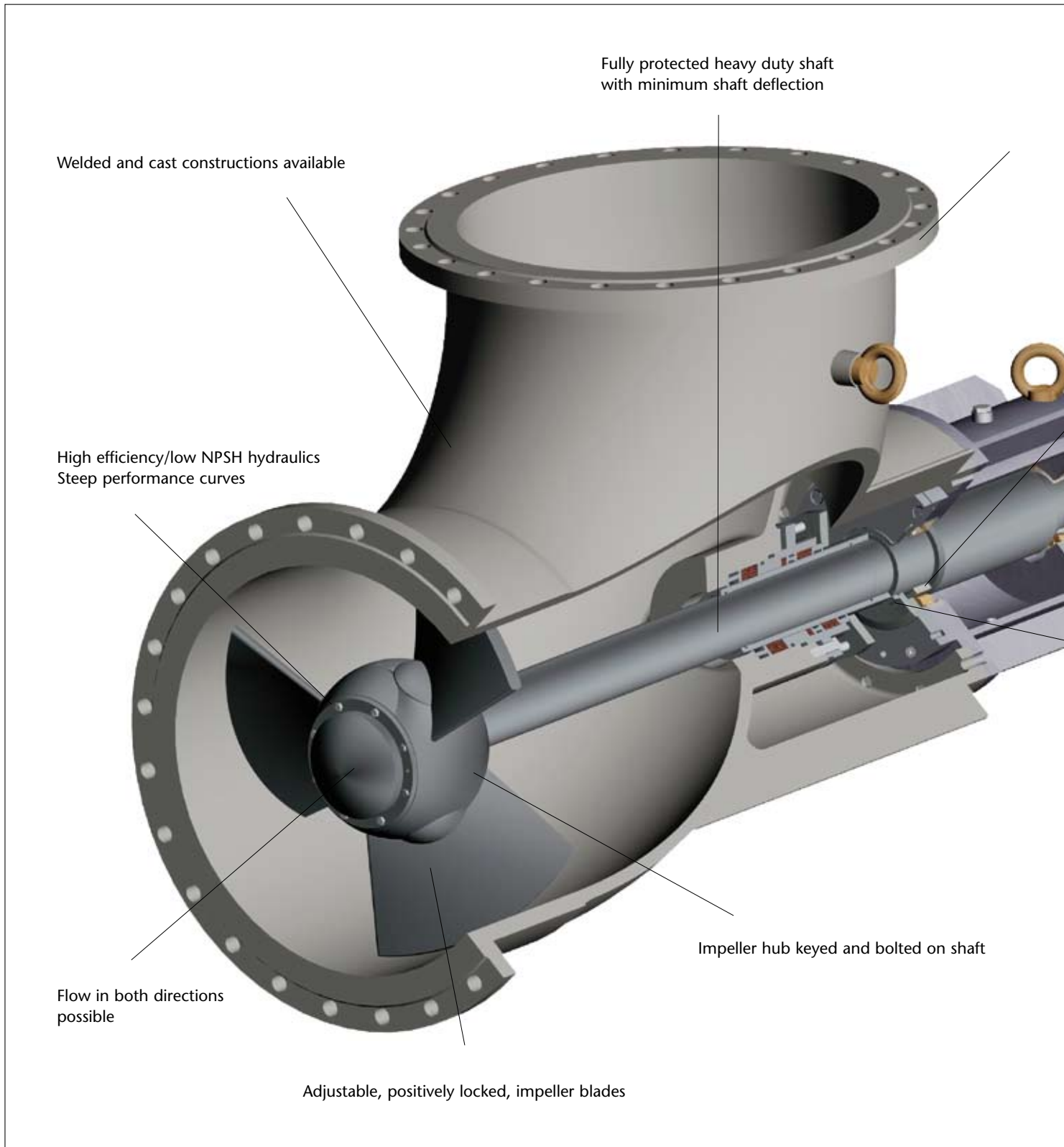

Shaft sealing options

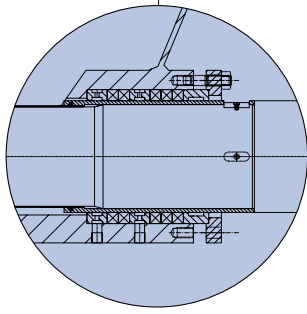

Stuffing box packing

Soft packing with double lantern ring

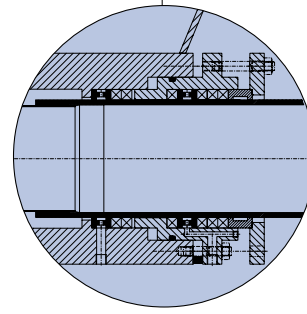

Stuffing box packing with shut-down device

Double stuffing box design. Soft packing with 1 lantern ring in the shut-down device and 1 lantern ring in the operating stuffing box.

DIN and ANSI flanges
DN300 (12") – DN2000 (80")

Heavy duty bearing arrangement

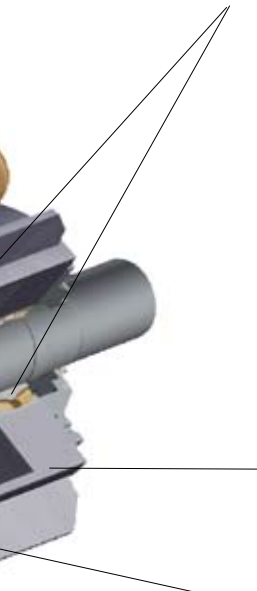

Oil lubricated bearing housing
(grease lubrication optional)

Labyrinth type deflector on both sides of bearing bracket

Specification

Applications

- Continuous circulation of corrosive/abrasive solutions, slurries, process wastes
- Crystallisation processes (brine, seawater)
- Chemical Industry
- Pulp and Paper Industry
- Regeneration plants
- Sugar
- Salt

Technical Data

- Capacity : Up to 80.000 m³/h
- Head : Up to 9.5 m
- Temperature : Up to 200 °C
- MAWP : up to 10 bar
- Flange drilling : DIN or ANSI
- Sizes : DN 300 (12") – DN 2000 (80")

Sealing Options

- Stuffed packing box
- Stuffed packing box with secondary stand-still packing device
- Single or double cartridge mechanical seal

Standard options pump materials

- 316 Stainless Steel
- Duplex Stainless Steel
- Super Duplex Stainless Steel
- Monel
- Other material options on client's request

Configurations

- Suspended, V-belt driven, with motor underslung to the pump
- Suspended, V-belt driven, with motor on separate base plate
- Suspended, gear box driven
- Foot mounted fabricated units
- Centreline mounted cast version

Options

- Guide vanes for improved efficiency & lifetime
- Back-pull out construction
- Wear ring at propeller running area in cast version
- Spring loaded base plate
- Housing wear ring optional



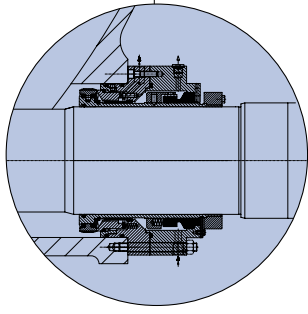

Mechanical seal

Single, double or tandem seal arrangement. Special slurry seals.

Q HYDRAULIC COVERAGE

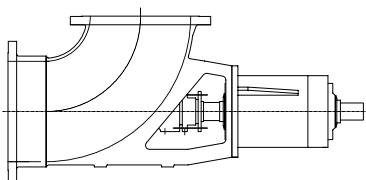
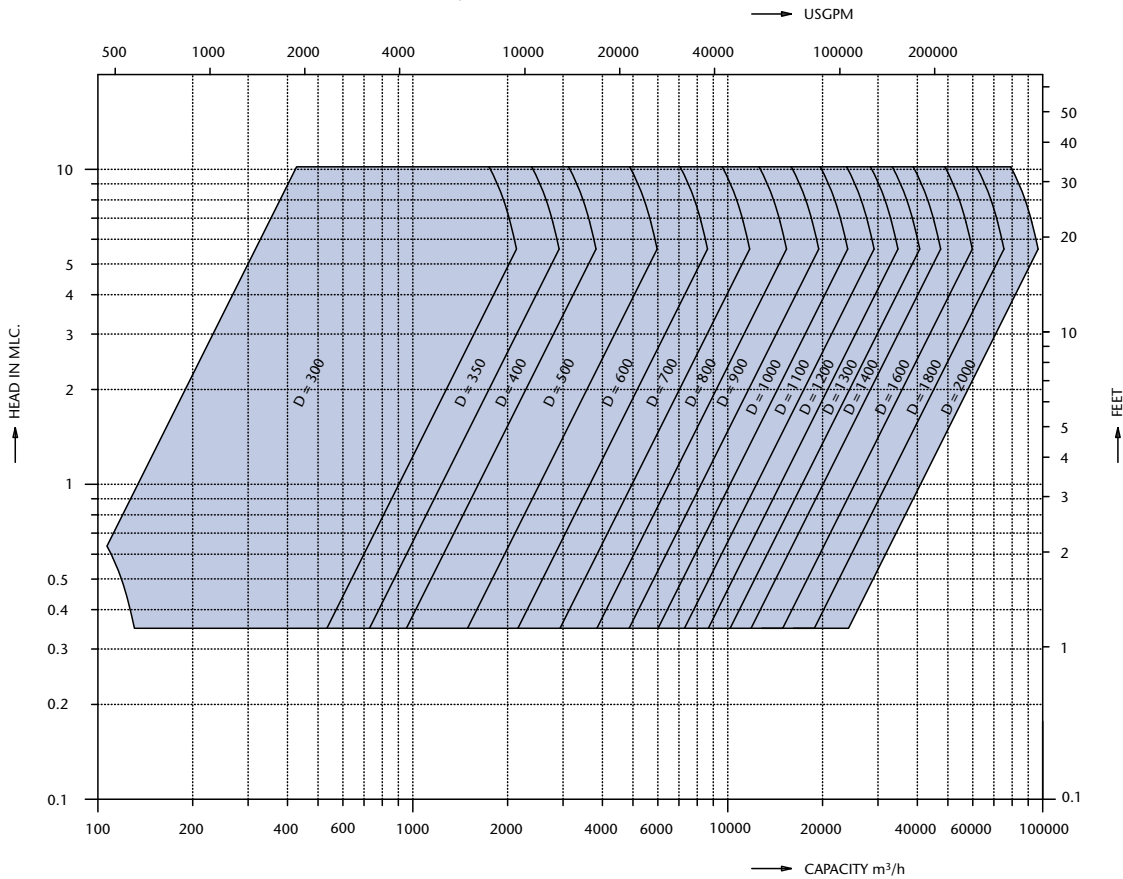

Series QL

Horizontal elbow design in cast construction. Oil lubricated. Drive by electric motor with V-belt transmission. Centreline-mounted on a common base frame or suspended in pipework with motor underslung. Alternatively with gear box or direct drive with frequency converter.

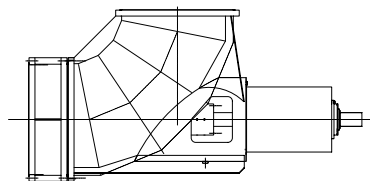

Series QCL

Horizontal elbow design in welded construction with separate pump casing. Oil lubricated. Drive by electric motor with V-belt transmission. Foot-mounted on a common base frame or suspended in pipework with motor mounted on a separate baseplate. Alternatively with gear box/cardan shaft or direct drive with frequency converter.

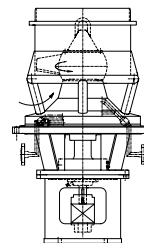

Series QCV

Bottom flange design for direct mounting to the reactor vessel. Drive arrangement in accordance with the actual situation.

Weir: Reliably innovative

Weir delivers innovative products. Weir utilises the well-proven "lean production system". This single flow, lean manufacturing process with dedicated production units means less wastage and greater efficiency, enabling us to provide the highest standard pumps and components.



Designed to simplify maintenance and reduce whole life costs

The WARMAN PUMPS are designed to make maintenance straightforward, minimise operation costs and increase product life span.

The WARMAN Q series of Axial Flow pumps are designed to meet arduous conditions e.g. salt evaporation plants. They are developed for high capacities and are designed to always operate at the Best Efficiency Point in combination with optimum NPSH values as a result of the specially designed propeller blades. Many years of experience, in combination with strengths in materials, research and development, product design and manufacturing excellence, results in a robust, reliable pump with excellent operability and long life.





Weir Minerals Netherlands b.v.

P.O. Box 249, 5900 AE Venlo, the Netherlands
Egtenrayseweg 9, NL-5928 PH Venlo
4495
Registration No.: 12032525

Tel: +31 (0)77 389 52 00
Fax: +31 (0)77 382 48 44
Email: weir@weirminerals.com
www.weirminerals.com

Excellent
Minerals
Solutions

