

**WARMAN®**  
Centrifugal Slurry Pumps

Excellent  
Minerals  
Solutions



**5000 Series Vertical Pumps**



# Warman® 5000 Series vertical pumps are designed for maximum flexibility and dependability in abrasive/corrosive applications

## Recognized worldwide for dependability

Warman® 5000 Series pumps feature heavy duty construction, long service life and easy maintenance. They are offered in a variety of materials to match your requirements, combining flexibility and dependability in abrasive/corrosive applications.

## Warman® 5000 Series pump features

- Cantilevered shaft design
- Double-suction, semi-open impeller
- Dual volute casing design
- Elastomer or abrasion-resistant metal construction
- Optional suction extensions
- Universal motor bracket
- Agitator option



Right: Mixing action of the agitator option

Below: Floor clean-up sump pump

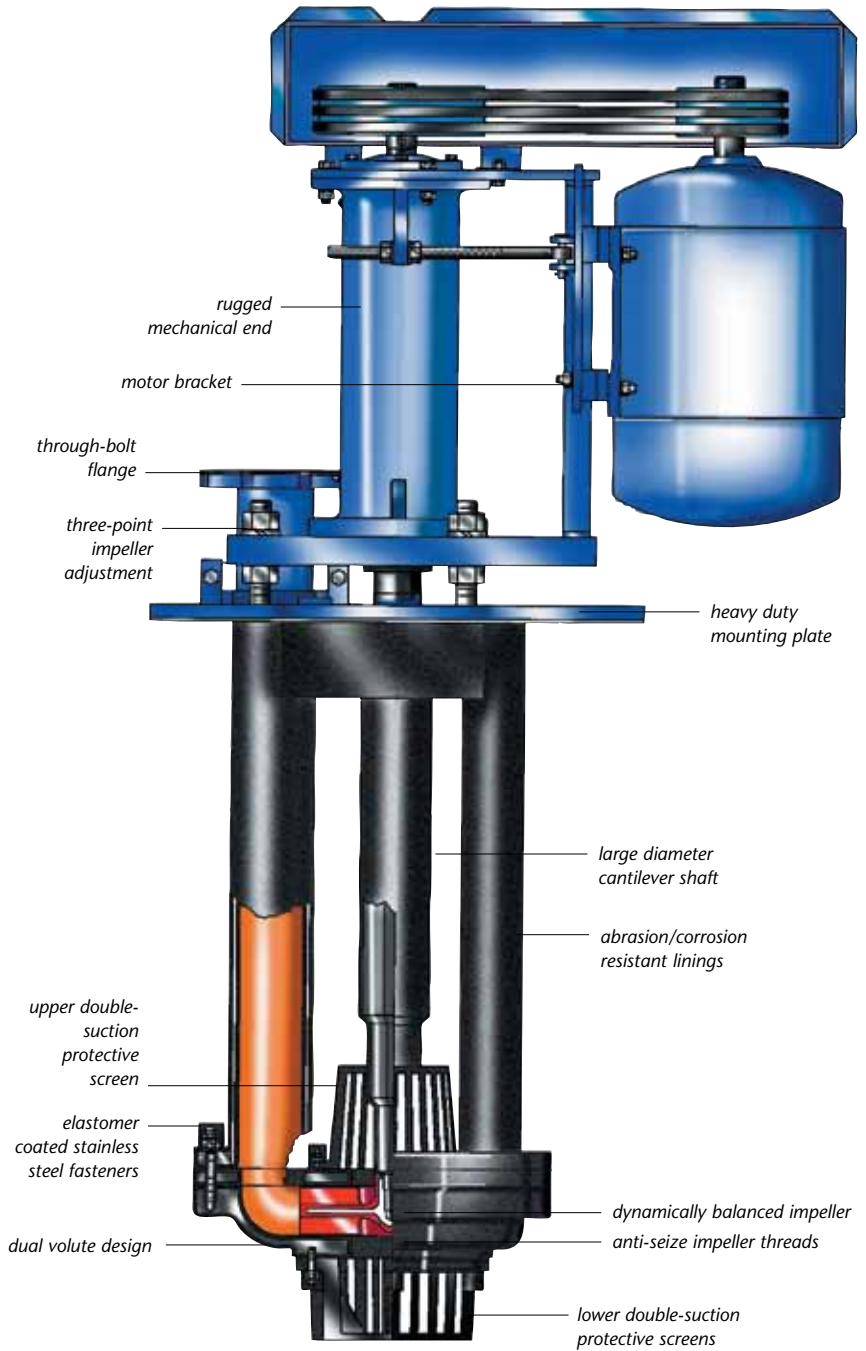

**Cantilever shaft**

The cantilever shaft design of the Warman® 5000 Series pump eliminates the need for submerged bearings, mechanical seals or packing. Shaft deflection throughout the entire operating range is minimized by using large diameter shafts, rugged pedestals and dual volute casings.

**Double-suction**

The double-suction, thrustless impeller design prevents air-locking and balances axial loads on the shaft and bearings. This design extends wear life and improves pumping efficiency.

**Dual volute hydraulics**

A unique dual volute casing balances radial forces on the impeller while minimizing shaft and bearings loads. Abrasive/corrosive fluids are pumped out through a single discharge pipe.

**Materials of construction**

Warman® 5000 Series vertical pumps are supplied in a variety of elastomers to meet service requirements. Abrasion-resistant models are lined inside. Acid-resistant models are lined inside and outside. All-metal pumps are available with cast iron or high chrome wet ends.

**Optional suction extensions**

Optional suction extensions are a cost effective alternative for lengthening the pump beyond the standard cantilever length.

**Universal motor bracket**

Universal motor bracket accommodates a wide range of motor sizes.

**Agitator option**

Agitator option keeps solids in suspension to eliminate settling in the sump.

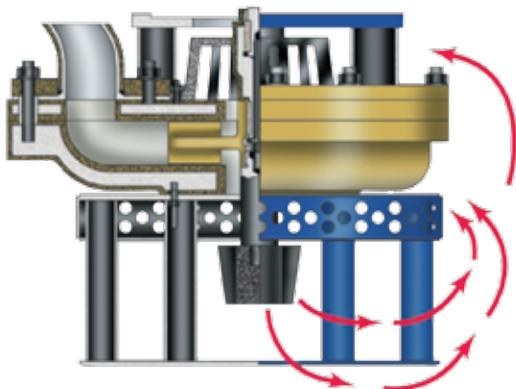

Agitator option

Size range:  
1.5" to 12" (40mm to 200mm)

Capacities:  
to 7,000 USGPM (1,600 m³/hr)

Heads:  
to 180 feet (55 meters)



12" Warman® 5000 Series pump installed in environmental containment sump

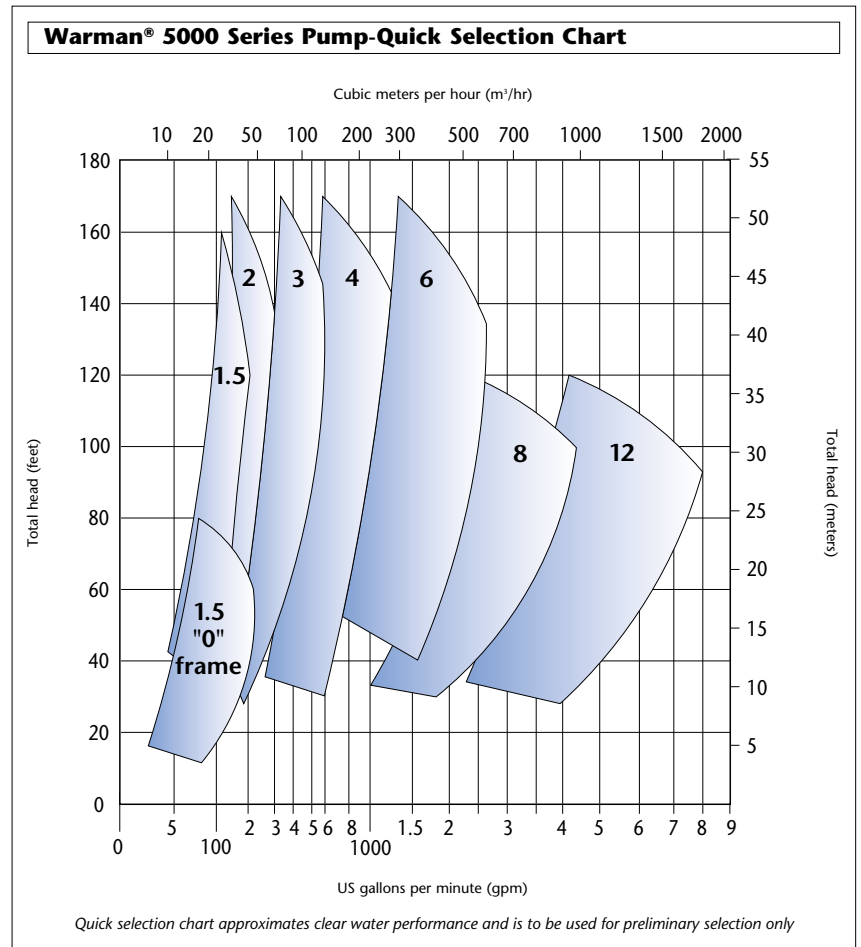

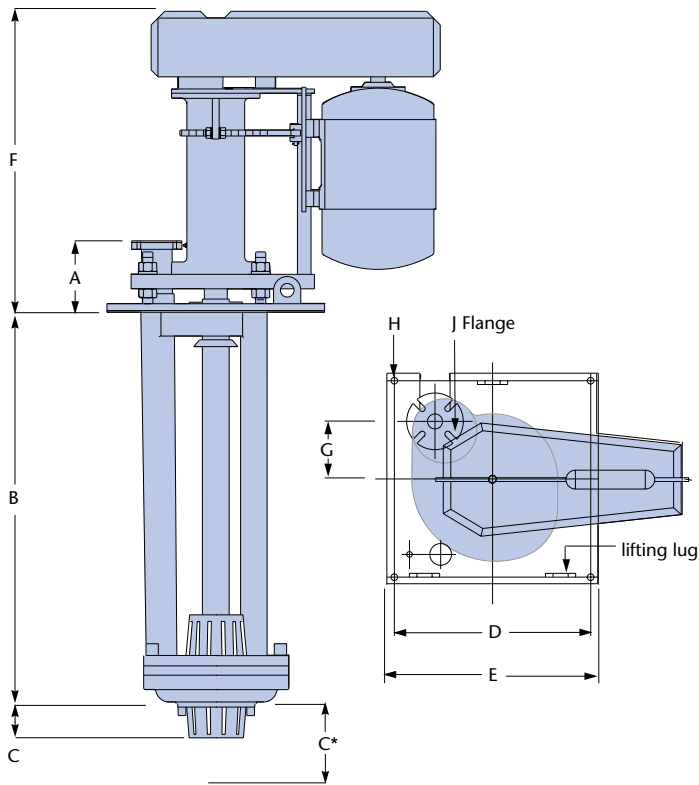

**Warman® 5000 Series Pump Dimensions (inches)**

Pump size	Mechanical end	A	B	C	C *	D	E	F	G	H	J flange 150# slotted
1.5	0	9.5	24, 36, 48	3.5	10.25	24	26	23	7.625	.875	1.5, 2
1.5	1	9.5	24, 36, 48	3.5	10.25	26	28	28.375	7.625	.875	1.5, 2
1.5	2	9.5	24, 36, 48, 60	3.5	10.25	26	28	34.875	7.625	.875	1.5, 2
1.5	3	9.5	24, 36, 48, 60, 72	3.5	10.25	26	28	43.0625	7.625	.875	1.5, 2
2	1	9.5	24, 36, 48	5	10.25	26	28	28.125	7.625	.875	2, 2.5, 3
2	2	9.5	24, 36, 48, 60	5	10.25	26	28	34.625	7.625	.875	2, 2.5, 3
2	3	9.5	24, 36, 48, 60, 72	5	10.25	26	28	42.75	7.625	.875	2, 2.5, 3
3	2	10.5	24, 36, 48, 60	5	10.25	30	32	35.25	8.625	1	3
3	3	10.5	36, 48, 60, 72	5	10.25	30	32	43.4375	8.625	1	3
3	4	10.5	36, 48, 60, 72	5	10.25	30	32	47.75	8.625	1	3
4	2	11	24, 36, 48, 60	6.0625	12.25	34	36	35.875	8.9375	1	4, 5, 6
4	3	11	36, 48, 60, 72	6.0625	12.25	34	36	43.4375	8.9375	1	4, 5, 6
4	4	11	36, 48, 60, 72	6.0625	12.25	34	36	47.75	8.9375	1	44, 5, 6
6	4	8.25	48, 60, 72	6.0625	12.25	41	44	49.75	12.625	1.125	6
6	5	8.25	48, 60, 72	6.0625	12.25	41	44	57	12.625	1.125	6
8	4	9.5	48, 60, 72	8	15.5	53	56	49.5	15.3125	1.125	8-
8	5	9.5	48, 60, 72	8	15.5	53	56	57	15.3125	1.125	8-

**Weir Minerals North America**

2701 S Stoughton Road, Madison WI 53716  
 PO Box 7610, Madison WI 53707  
 USA

Tel: 608 221 2261  
 Fax: 608 221 5810  
[www.weirminerals.com](http://www.weirminerals.com)

Excellent  
 Minerals  
 Solutions

