

**Warman SJ submersible dewatering pump**

The Warman SJ submersible dewatering pumps represent an optimal combination of ruggedness, durability, hydraulics and materials technology. These pumps are designed to perform in the most arduous submersible mine and quarry dewatering applications. Warman SJ pumps are equipped for immediate use, their robust but low weight design makes installation and operation easy and safe

**Warman SJ standard features**

- Heavy duty construction with lightweight portability – durability and strength with ease of transport, maintenance and less downtime
- Optimum mix of wear resistant materials – full utilization of wearing parts for maximum wear life
- Great value with a modular design – easily adjusted and replaced wear parts for less downtime
- Common components between SJ sizes – reduced spares inventory and ease of maintenance
- Simple access to separate sealed electrical junction box – ease of cable replacement
- Temperature sensors fitted to motor windings allow automatic shutdown in the event of overheating – pump can run dry without risk of burnout
- High specification mining cable as standard – ready to use out of the box
- Silicon carbide faces on primary seal – longest life in dirty water applications

**Warman SJ benefit to the customer**

- Ease of portability, installation and maintenance, less downtime, maximum wear life and efficient hydraulic performance give the customer – the lowest total cost of ownership

The premium submersible mine dewatering pump from the global slurry pump specialists



*Warman 150-400SJ60-4*

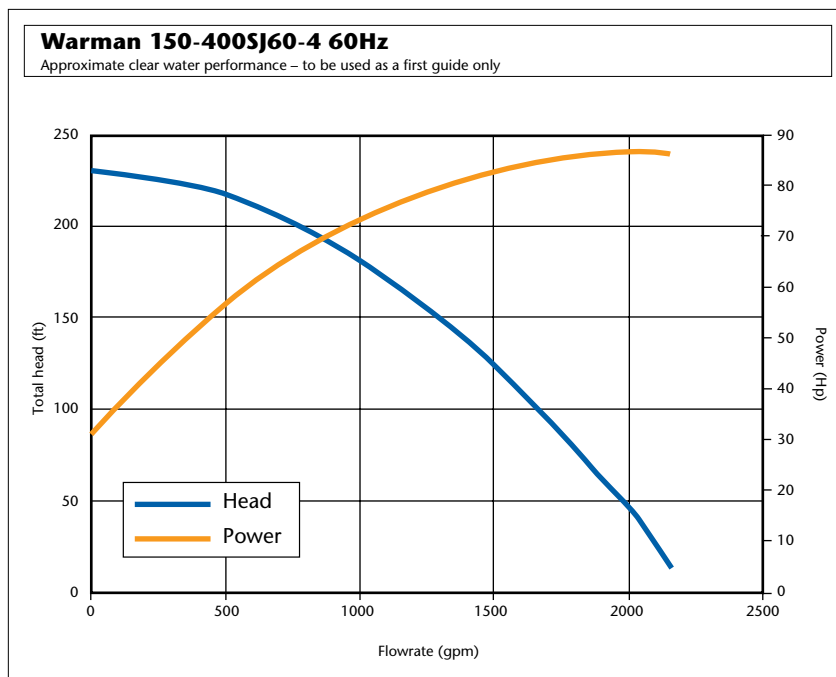

**Size range (discharge)**

6" NPT

**Capacities to**

2155 gpm

**Heads to**

227 feet

**Applications**

Underground mine dewatering

Opencast mine dewatering

Alluvial mining level control

Sand, gravel and hard rock quarrying

Clarified water

Mineral processing plants

## Pump

Maximum submergence: 65.5 feet  
Maximum working pressure: 145 psi  
Max SG: 1.1  
pH range: 5–8  
Strainer holes: 0.55 inch diameter  
Weight (including 20 m cable): 1300 lbs

## Electric motor

3-phase squirrel-cage induction motor  
Protection class: IP 68. Class F insulation  
Motor rating P2: 94 Hp (70 kW)  
Speed: 1732 rpm  
Starting: Direct on line

High specification rubber-sheathed flexible mining cable suitable for underground mining, open-cast mining, quarries and other similar applications  
NSSH U .../3E, DIN VDE 0250, Part 812, MSHA P-189-3, WUG-GE-104/97

## Shaft seal

Double mechanical seal in oil bath  
Primary seal: Silicon carbide on silicon carbide  
Secondary seal: Stainless steel on antimony treated carbon

## Bearings

Upper bearing: Single-row deep groove ball bearing  
Lower bearing: Double angular contact ball bearing

## Materials of construction

Component	Material	Code
Castings	Aluminium	
Casing & fasteners	Stainless steel	C22
Shaft	Stainless steel	C21
Impeller	High chrome iron	A05
Wear plate	Polyurethane	U01
Diffuser	Nitrile rubber	S12
Back Plate	Nitrile rubber	S12

## Outline dimensions (mm)

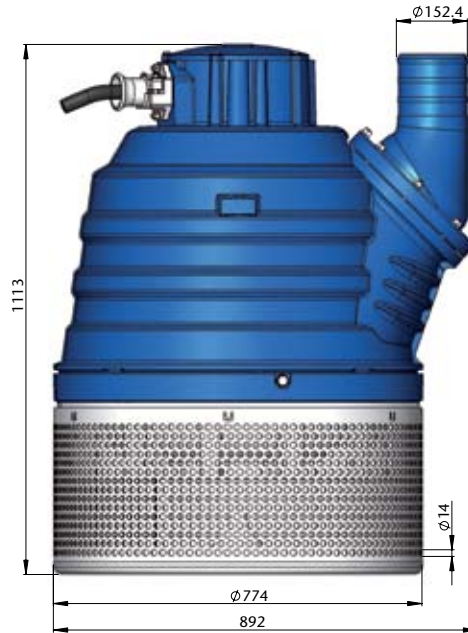

**WARMAN®** Centrifugal Slurry Pumps  
**GEHO®** Positive Displacement Slurry Pumps  
**CAVEX®** Hydrocyclones  
**ISOGATE®** Slurry Valves  
**VULCO®** Wear Resistant Linings



For further information on Weir Minerals products or services, contact the nearest sales office or visit [www.weirminerals.com](http://www.weirminerals.com)

### Weir Minerals North America–Hazleton

225 N Cedar, Hazleton PA 18201  
PO Box 488, Hazleton PA 18201  
USA

Tel: 570 455 7711  
Fax: 570 459 2586  
[www.weirminerals.com](http://www.weirminerals.com)

Slurry  
Equipment  
Solutions

